

MOTORES ELÉCTRICOS serie TRIFÁSICA

SIEMENS

CARACTERÍSTICAS:

- Protección IP 55.
- Caja de bornes superior (hasta tamaño 100).
- Aislamiento clase F.
- Ejecución B3.
- Pintura anticorrosiva RAL 7016 gris antracita.
- Bifrecuencia 50Hz + 60 Hz.

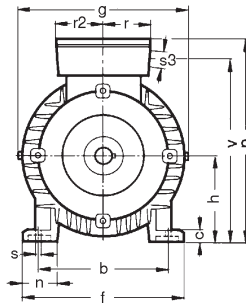
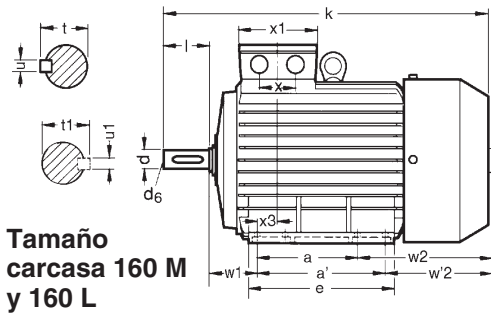
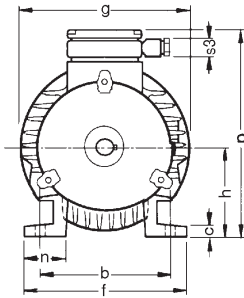
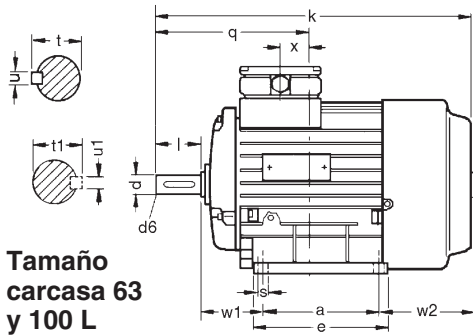
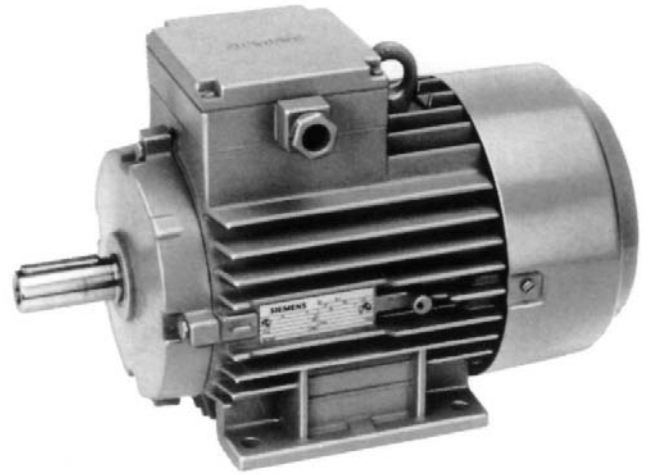

Potencia (CV)	Tamaño	Tensión
1/3	71	220/380V III
1/2	71	220/380V III
3/4	80	220/380V III
1	80	220/380V III
1,5	90 S	220/380V III
2	90 L	220/380V III
3	100 L	220/380V III
4	100 L	220/380V III
5,5	112 M	220/380V III
5,5	112 M	380/660V III
7,5	132 S	220/380V III
7,5	132 S	380/660V III
10	132 S	380/660V III
15	160 M	380/660V III
20	160 L	380/660V III

Nota: Consultar otras potencias y tensiones

DIMENSIONES:

Tamaño carcasa	DIN	a	a'	b	c	d	e	f	g	g1	h	k	k1	n	p	q	r	r2	s
	CEI	B	B'	A	HA		BB	AB	AC	AG	H	L	LC	AA	HD	LF	AG	AS	K
71		90	—	112	8	14	106	132	132	—	71	231	266	32	173	120	—	—	7
80		100	—	125	9	19	126	150	154	—	80	268	313	36	198	140	—	—	10
90 S		100	—	140	10	24	127	167	172	—	90	292	347	39	214	152	—	—	10
90 L		125	—	140	10	24	145	167	172	—	90	312	367	39	214	162	—	—	10
100 L		140	—	160	12	28	167	188	198	—	100	383	454	42	240	195	—	—	12
112 M		140	—	190	15	28	195	225	240	322	112	426	493	45	267	210,5	—	—	12
132 S		140	—	216	17	38	202	255	280	358	132	483	570	47	306	246	—	—	12
132 M		178	—	216	17	38	240	255	280	358	132	521	608	47	306	265	—	—	12
160 M		210	—	254	22	42	254	314	324	—	160	618	742	63	399	—	96,5	91,5	15
160 L		210	254	254	22	42	298	314	324	—	160	662	786	63	399	—	96,5	91,5	15